

**\*RECOMMENDED SERVICE BULLETIN\***

**NUMBER:** SB11-09  
**REVISION:** 01  
**DATE:** 08/01/2011

**SUBJECT:** BRAKE MASTER CYLINDER INSPECTION

**EFFECTIVITY:**

KODIAK 100 Series Aircraft Serial Numbers: 100-0001 through 100-0052.

**SUMMARY:**

It has been determined that the pin and bushings securing the brake master cylinder into position may have the potential to move within the bracket.

**ACTION:**

Quest is recommending a one time inspection of the master brake cylinder support bracket, as well as the installation of four (4) new washers.

**COMPLIANCE:**

This Recommended Service Bulletin should be complied with on or before the next 100 hour, annual inspection, or scheduled maintenance, whichever comes first.

**LOG OF CHANGES:**

Revision:	Date:	Description of Change:
00	07/15/2011	Initial Release
01	08/01/2011	Summary: Clarified Parts and Tools Included: Updated and Clarified Parts and Tools Not Included: Removed Detail D: Updated to reflect cotter pin part number.

**ATTACHED DOCUMENTS:**

Document #:	Date:	Document Title:
N/A	N/A	N/A

**PARTS, TOOLS, AND EQUIPMENT:**

The parts, tools and equipment listed below are needed in order to complete the instructions contained within.

Parts and/or Tools needed to comply with this Service Bulletin:

Item	Quantity	Part Number	Description
1	4	NAS1149F0332P	Washer
2	2	MS24665-132	Cotter Pin

**FAA APPROVED:**

The modification described in this Recommended Service Bulletin has shown compliance with the applicable Federal Aviation Regulations and is FAA Approved.

**INDUSTRY SUPPORT INFORMATION:**

N/A

Quest Aircraft Company, LLC  
© Copyright 2011  
All Rights Reserved  
No part of this document may be reproduced, copied, transmitted, disseminated, downloaded or stored in any storage medium,  
for any purpose without the express prior written consent of Quest Aircraft Company, LLC.

**\*RECOMMENDED SERVICE BULLETIN\***

**\*RECOMMENDED SERVICE BULLETIN\***

**\*RECOMMENDED SERVICE BULLETIN\***

**NUMBER:** SB11-09  
**REVISION:** 01  
**DATE:** 08/01/2011

**SUBJECT:** BRAKE MASTER CYLINDER INSPECTION

**WEIGHT AND BALANCE:**

Negligible

**MANPOWER:**

The instructions contained in this Recommended Service Bulletin will take approximately:

- 1 Hour

**CREDIT AND WARRANTY INFORMATION:**

Quest Aircraft Company will reimburse for the cost of this modification up to \$75.00 for aircraft still under factory warranty. For reimbursement send Quest Aircraft Company a copy of the modification record and serial number of the aircraft on which the modification was completed.

*Quest Customer Service  
Service Bulletin SB11-09  
Phone: (208)263-1111 Toll Free: 1(866)263-1112  
Email: [Customercare@questaircraft.com](mailto:Customercare@questaircraft.com)*

**COMPLETION:**

Record the work performed in the *KODIAK 100 Maintenance Records*.

**ACCOMPLISHMENT INSTRUCTIONS:**

Accomplishment Instructions are listed in the next section of this Service Bulletin.

**ATTACHED DOCUMENTS:**

N/A

**SPECIAL INSTRUCTIONS:**

N/A

**\*RECOMMENDED SERVICE BULLETIN\***

**\*RECOMMENDED SERVICE BULLETIN\***

## 1. BRAKE MASTER CYLINDER INSPECTION

1. Remove the cotter pin (P/N **MS24665-132**) securing the pin (P/N **MS20392-2C27**) into position on both the right and left brake master cylinders as shown in **Figure 1-1, Detail B**.
2. Remove the two (2) pins (P/N **MS20392-2C27**) and two (2) washers (P/N **NAS1149F0363P**) from the aircraft. Discard the two (2) washers (P/N **NAS1149F0363P**) and retain the two (2) pins (P/N **MS20392-2C27**) for use in **Section 2**.
3. Move the right brake master cylinder (P/N **CM2000-1**) AFT of the right hand brake master support bracket (P/N **100-617-0034**).
4. Move the left brake master cylinder (P/N **CM2000-1**) AFT of the left hand brake master support bracket (P/N **100-617-0015**).
5. Verify the bushings are secure in both the left hand brake master support bracket (P/N **100-617-0015**) and the right hand brake master support bracket (P/N **100-617-0034**) as shown in **Figure 1-1, Detail C**.
6. If bushings are loose, contact Quest Aircraft Company for further instructions. If bushings are secure, proceed to **Section 2**.

## 2. WASHER INSTALLATION

1. Position and secure the left brake master cylinder (P/N **CM2000-1**) using the pin (P/N **MS20392-2C27**), two (2) washers (P/N **NAS1149F0332P**), and a cotter pin (P/N **MS24665-132**) as shown in **Figure 1-1, Detail D**.
2. Position and secure the right brake master cylinder (P/N **CM2000-1**) using the pin (P/N **MS20392-2C27**), two (2) washers (P/N **NAS1149F0332P**), and a cotter pin (P/N **MS24665-132**) as shown in **Figure 1-1, Detail D**.

## 3. RECORD WORK PERFORMED IN KODIAK LOG BOOKS

Upon completion, record all work performed in the appropriate KODIAK maintenance records.

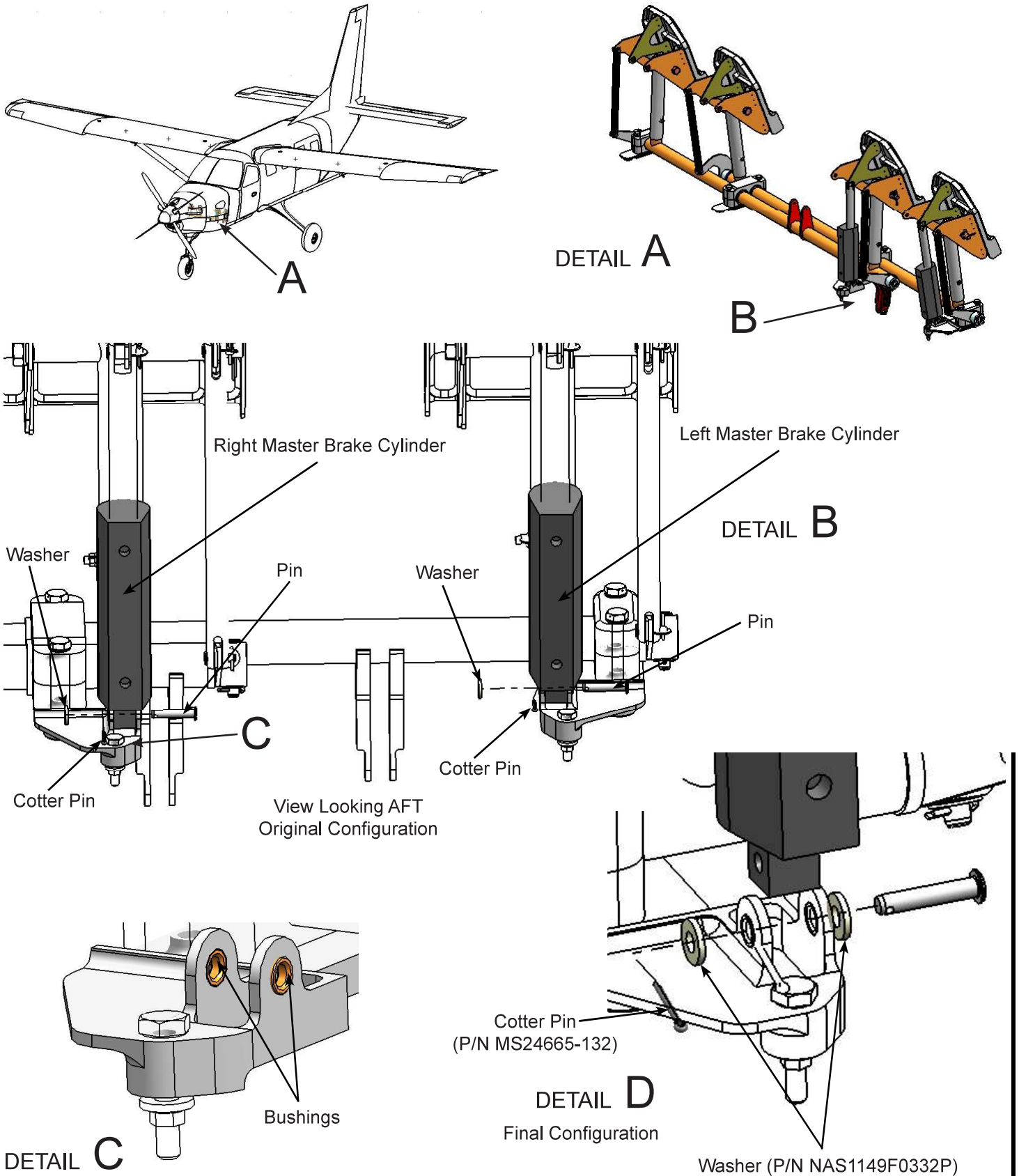

**Figure 1-1: Master Brake Cylinder Inspection and Washer Installation**