

MANDATORY SERVICE BULLETIN**NUMBER:** SB-023**REVISION:** A**DATE:** 12/01/2009**SUBJECT:** ELECTRICAL SYSTEM; Main Power Feed Cable**EFFECTIVITY:**

MAIN POWER FEED CABLE INSPECTION: KODIAK 100 Series Aircraft Serial Numbers:

- **100-0001 thru 100-0029**

SUBJECT:

Quest Aircraft Company LLC. is mandating a one-time inspection to inspect the main power feed cable (main bus) on the electrical system for chafing which could occur if the main wire bundle was installed with excess slack. This Mandatory Service Bulletin provides directions for a one-time inspection and also provides parts to provide positive restraint if required.

AFFECTED PARTS:

- 100-617-2150 (Rudder Bungee)
- PD026_V001 (Main Power Feed Cable)
- PD025_V001_R02 (Main Power Feed Cable)
- 100-270-4001 (Subfloor Center FWD)

AFFECTED MANUALS AND PUBLICATIONS:

- N/A

FAA APPROVED:

The resultant alteration to the electrical system described in this Service Bulletin has shown compliance with the applicable Federal Aviation Regulations and is FAA Approved.

CONTINUED ON NEXT PAGE...Quest Aircraft Company, LLC
© Copyright 2009
All Rights Reserved

No part of this document may be reproduced, copied, transmitted, disseminated, downloaded or stored in any storage medium, for any purpose without the express prior written consent of Quest Aircraft Company, LLC.

MANDATORY SERVICE BULLETIN**NUMBER:** SB-023**REVISION:** A**DATE:** 12/01/2009**SUBJECT:** ELECTRICAL SYSTEM; Main Power Feed Cable**COMPLIANCE:**

Main Power Feed Cable Inspection must be completed within the next 20 flight hours.

INDUSTRY SUPPORT INFORMATION:

N/A

WEIGHT AND BALANCE:

The procedure contained in this Mandatory Service Bulletin does not alter the weight and balance of the aircraft.

MANPOWER:

The instructions contained in this Service Bulletin will take approximately:

- *Inspection/Procedure 1: 2.5 hours*

CREDIT and WARRANTY INFORMATION:

N/A

COMPLETION:

Update the KODIAK 100 Maintenance Log Books.

ACCOMPLISHMENT INSTRUCTIONS:

Accomplishment Instructions are listed in the next section of this Mandatory Service Bulletin.

MANDATORY SERVICE BULLETIN***MANDATORY SERVICE BULLETIN***

LOG OF CHANGES

Revision:	Date:	Description of Change:
A	12/01/2009	Initial Release

ATTACHED DOCUMENTS

Document #:	Date:	Document Title:
N/A	N/A	N/A

SPECIAL SAFETY INSTRUCTIONS

PARTS, TOOLS, AND EQUIPMENT

The following parts, tools, and equipment are listed below in order to complete the instructions contained within.

Parts and Tools Included in this Service Kit:

Part Number	Description	Quantity
100-828-4051	L Bracket	1
MS21919WDG14	Adel Clamp	1
AN3-4A	Bolt	1
MS21044N3	Nut	1
CR3213-4	ARN-4	2

Special Tools Required that are Not Provided in this Service Kit:

Tool Name	Tool Duty
N/A	None Required

1. MAIN WIRE BUNDLE INSPECTION/PROCEDURE

1.1 LOCATION OF MAIN POWER FEED CABLE

Locate the Main Power Feed Cable shown in Figure 1-1.

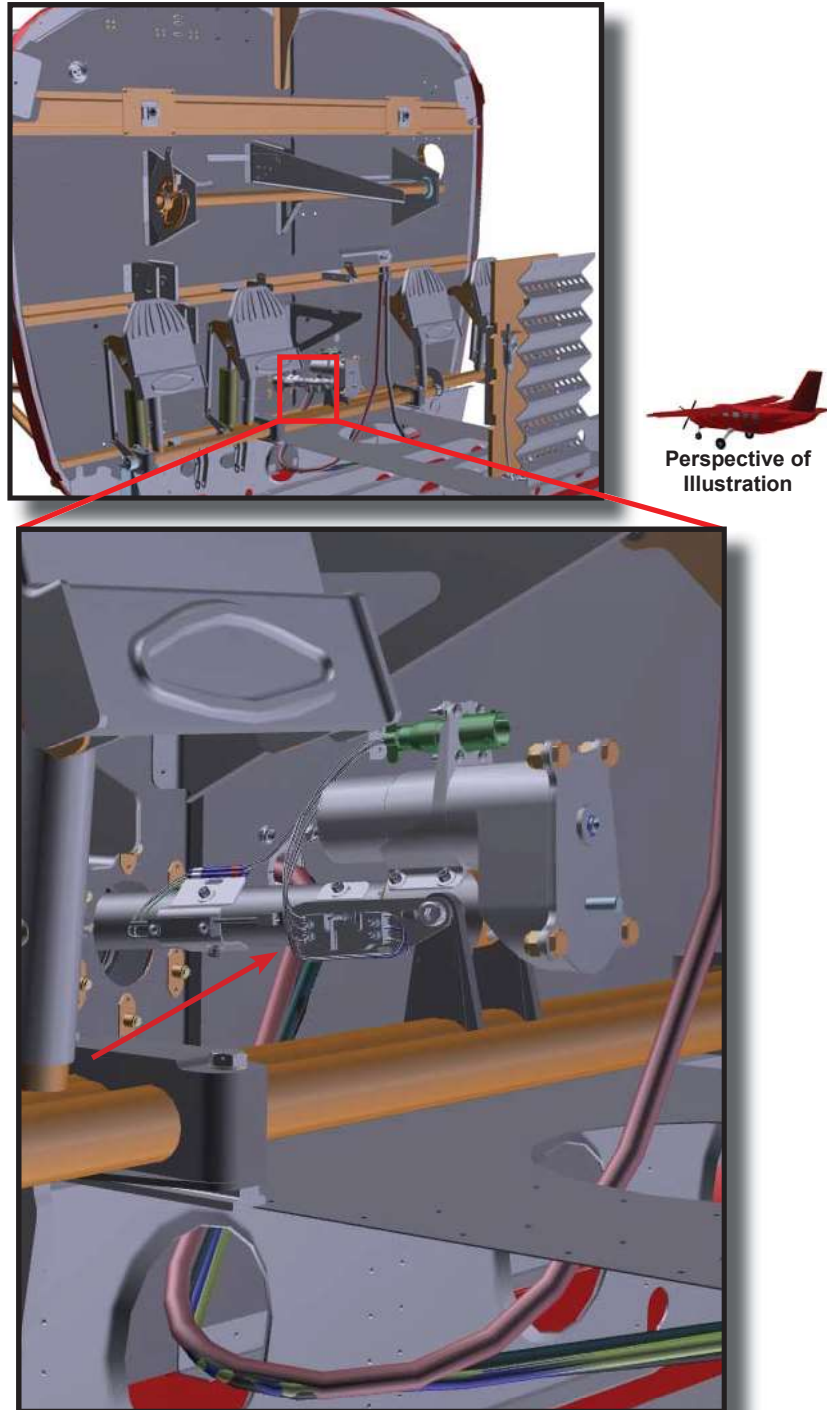

Figure 1-1: Location of the Main Power Feed Cable

1.2 INSPECTION OF THE MAIN POWER FEED CABLE

Turn the Nose Wheel fully to the left in order to position the Rudder Bungee at its lowest position. Placing two fingers under the Main Power Feed Cable and using light pressure, push upwards. If the Main Power Feed Cable comes in contact with the Rudder Bungee, proceed to **Step 1.3**. Also if the Main Power Feed Cable is able to come within 0.50 of the break lines below, proceed to **Step 1.3**. If the Main Power Feed Cable does not come in contact with the Rudder Bungee, proceed to **Step 1.6**.

1.3 NEW RIVET HOLE LOCATION

Locate the Rivets and mark the locations for drilling indicated in **Figure 1-2**. Using a #30 drill bit carefully drill out the holes for the **L Bracket (P/N 100-828-4051)**.

NOTE: The holes in the **L Bracket (P/N 100-828-4051)** may need to be widened with the #30 drill to match the diameter of the **ARN-4 (P/N CR3213-4)** rivets.

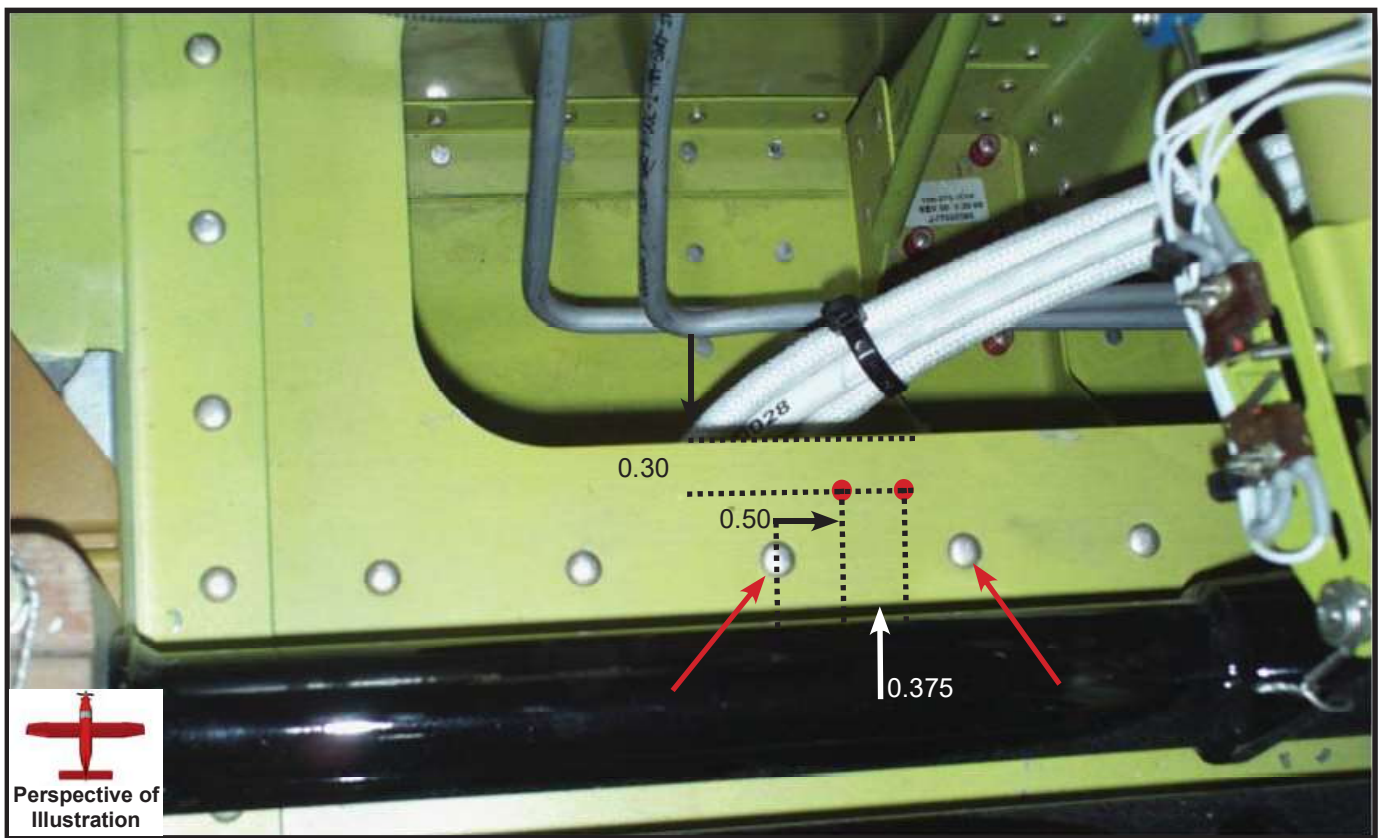
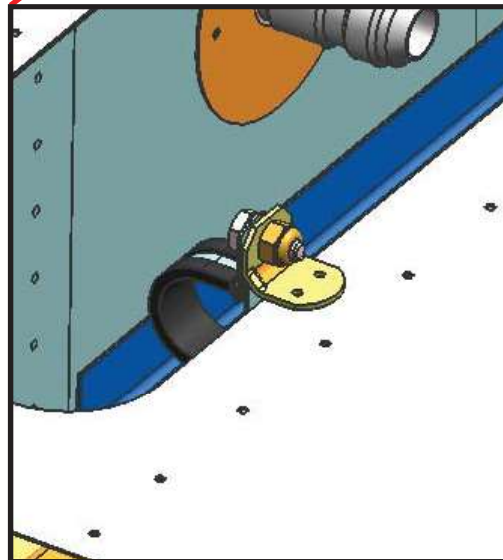
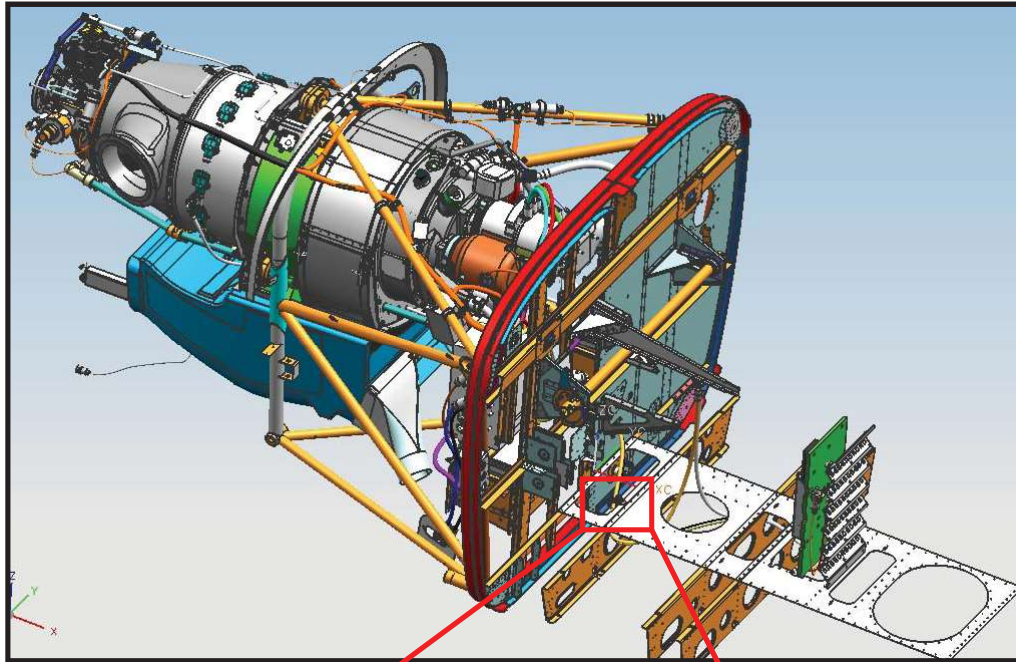

Figure 1-2: Measurements for Rivet Hole Locations

WARNING: The metal shavings that result from drilling need to be cleaned up. Make sure that the shavings do not get imbedded into any of the electrical wire bundles.

1.4 INSTALLATION OF BUNDLE RESTRAINING BRACKET

Secure the **L Bracket (P/N 100-828-4051)** to the **Subfloor (P/N 100-270-4001)** with the **ARN-4 (P/N CR3213-4)**. Feed wires through the **Adel Clamp (P/N MS21919WDG14)** and use the **Nut (P/N MS21044N-3)** and **Bolt (P/N AN3-4A)** to secure the **Adel Clamp (P/N MS21919WDG14)** to the **L Bracket (P/N 100-828-4051)**. Ensure that the bolt has sufficient thread engagement.



Perspective of Illustration

Figure 1-3: Wire Bundle Restraining System

1.5 RE-INSPECTION OF MAIN POWER FEED CABLE

With the Nose Wheel fully to the left, re-inspect the Main Power Feed Cable. Insure that the Main Power Feed Cable does not come in contact with the Rudder Bungee and that it also has at least 0.5 clearance of the break lines below.

1.6 MAIN POWER FEED CABLE REPAIR (IF NECESSARY)

If any damage has occurred to the fiberglass insulation of the Main Power Feed Cable, repairs must be made. Report extent of damage to Quest and await repair instructions.

1.7 ANNOTATE WORK PERFORMED IN KODIAK LOG BOOKS

Upon completion, annotate all work performed in the appropriate KODIAK Log Books.

-----END OF INSTRUCTIONS-----