

**\*MANDATORY SERVICE BULLETIN\*****NUMBER:** SB12-06**REVISION:** 00**DATE:** June 20, 2012**SUBJECT:** WING SKIN FAY SURFACE SEAL APPLICATION INSTRUCTIONS**EFFECTIVITY:**

KODIAK 100 Series Aircraft Serial Numbers: 100-0001 thru 100-0049

**SUMMARY:**

The accompanying Field Service Instruction provides guidance for the application of a fay surface seal to the wing skin lap joint underneath both wing fuel bays.

**COMPLIANCE:**

This Mandatory Service Bulletin must be complied with on or before the next Annual Inspection.

**ATTACHED DOCUMENTS:**

Document #:	Revision:	Document Title:
FSI-025	00	WING SKIN FAY SURFACE SEAL APPLICATION INSTRUCTIONS

**FAA APPROVAL STATUS:**

The instructions attached to this Service Bulletin have demonstrated compliance with all applicable Federal Aviation Regulations and are approved by the Federal Aviation Administration.

**CREDIT AND WARRANTY INFORMATION:**

Quest Aircraft Company will reimburse for the cost of this modification up to \$170.00. For reimbursement send Quest Aircraft Company a copy of the maintenance record, completed KODIAK 100 Warranty Claim Form, and an invoice that does not exceed the amount listed above.

**Quest Customer Service****Service Bulletin: SB12-06****Phone: (208)263-1111 Toll Free: 1(866)263-1112****Email: [Customercare@questaircraft.com](mailto:Customercare@questaircraft.com)****SPECIAL INSTRUCTIONS:**

The Service Kit for this Service Bulletin contains a consumable with a short shelf life. Ordering this Kit too far in advance of planned use could result in product expiring and replacement at the customer's expense. Contact Quest Customer Service for more information.



## FIELD SERVICE INSTRUCTION

TITLE: Wing Skin Fay Surface Seal Application Instructions

SERIAL RANGE: 100-0001 thru 100-0049

JASC CODE: 5730

PAGE: 1 of 7  
REPORT NO.: FSI-025  
REVISION: 00

### SUBJECT

This Field Service Instruction provides guidance for the application of a fay surface seal to the wing skin lap joint underneath both wing fuel bays.

---

### AFFECTED MANUALS AND PUBLICATIONS

None

---

### INDUSTRY REFERENCES

None

---

### WEIGHT AND BALANCE

Negligible

---

### MANPOWER

The estimated man-hours and minimum number of persons required to perform this Field Service Instruction are listed below. The "Minimum Persons" refers only to maintenance personnel or installers, and unless otherwise specified within this instruction does not include additional personnel that may be needed solely to comply with safety requirements (for example, safety observers that are not performing tasks within this instruction). It is the responsibility of maintenance personnel to comply with safety requirements, including having a safety observer available as needed.

**Estimated Man-hours: 2 hours**

**Minimum Persons: 1 person**

If more than the minimum personnel perform this instruction, the actual man-hours required may be reduced due to increased efficiencies. As appropriate, Quest encourages the use of additional personnel; man-hour estimates are based on the minimum personnel required.

---

### RECORD OF COMPLETION

Update the appropriate maintenance records.

---

Quest Aircraft Company, LLC  
1200 Turbine Drive  
Sandpoint, ID 83864



# FIELD SERVICE INSTRUCTION

TITLE: Wing Skin Fay Surface Seal Application Instructions

SERIAL RANGE: 100-0001 thru 100-0049

JASC CODE: 5730

PAGE: 2 of 7  
REPORT NO.: FSI-025  
REVISION: 00

## REVISION RECORD

REV	PAGE	CHANGE DESCRIPTION
00	All	Initial Release



# FIELD SERVICE INSTRUCTION

TITLE: Wing Skin Fay Surface Seal Application Instructions

SERIAL RANGE: 100-0001 thru 100-0049

JASC CODE: 5730

PAGE: 3 of 7

REPORT NO.: FSI-025

REVISION: 00

## TABLE OF CONTENTS

REVISION RECORD.....2

TABLE OF CONTENTS.....3

1. Special Safety Instructions.....4

    1.1 Warnings .....4

    1.2 Cautions.....4

    1.3 Notes.....4

2. Parts, Tools, and Equipment .....4

    Table 2-1: Parts and Tools Included in the Service Kit<sup>1</sup> .....4

    Table 2-2: Consumables Included in the Service Kit<sup>1</sup> .....4

    Table 2-3: Serial-Number-Specific Parts Included in the Service Kit .....4

    Table 2-4: Parts and Tools NOT Included in the Service Kit .....4

3. General.....5

    Figure 3-1: Wing Modification Area .....5

4. Preparation .....5

    4.1 Wing Fairing Removal .....5

        Figure 4-1: Fay surface Seal Access Hole Location .....5

5. Instructions.....6

    5.1 Surface Preparation .....6

    5.2 Drill Procedures.....6

        Figure 5-1: Fay surface Seal Access Hole Location .....6

    5.3 Sealant Installation .....6

        Figure 5-2: Shim Installation .....7

        Figure 5-3: Shim Installation .....7

    5.4 Complete Sealant Installation on Both Wings .....7

    5.5 Wing Fairing Installation.....7

6. Completion.....7



# FIELD SERVICE INSTRUCTION

TITLE: Wing Skin Fay Surface Seal Application Instructions

SERIAL RANGE: 100-0001 thru 100-0049

JASC CODE: 5730

PAGE: 4 of 7

REPORT NO.: FSI-025

REVISION: 00

## 1. Special Safety Instructions

### 1.1 Warnings

Failure to comply with “Warnings” contained in this instruction may result in financial loss, significant delay in the completion time, and/or serious injury to personnel.

### 1.2 Cautions

Failure to comply with “Cautions” contained in this instruction may result in the destruction of components, unnecessary complications, the need to reverse completed work, and/or delays in the completion time.

### 1.3 Notes

“Notes” are provided when additional information may lead to an increase in efficiency.

## 2. Parts, Tools, and Equipment

The following tables describe the parts, tools, and equipment necessary to successfully complete this instruction. Where applicable, reference to drawings provided with this instruction is provided.

**Table 2-1: Parts and Tools Included in the Service Kit<sup>1</sup>**

Item #	Part No.	Qty	Description	Drawing No.	Dwg Item #
2-1-1	8672	6"	Polyurethane Protective Tape	N/A	N/A
2-1-2	137499	1	Fine Tipped Syringe	N/A	N/A

1: Parts listed will be shipped upon request.

**Table 2-2: Consumables Included in the Service Kit<sup>1</sup>**

Item #	Part No.	Qty	Description	Drawing No.	Dwg Item #
2-2-1	P/S 890-A2	1	Fuel Tank Sealant <sup>2</sup>	N/A	N/A

1: Consumables may be shipped separately from the primary kit.

2: Due to the short shelf life of this product, Quest Aircraft will be stocking a small quantity and will replenish the supply as needed. A short lead time in receiving this product may result.

**Table 2-3: Serial-Number-Specific Parts Included in the Service Kit**

Item #	Part No.	Qty	Description	Drawing No.	Dwg Item #
2-3-1	N/A	-	N/A	N/A	N/A

**Table 2-4: Parts and Tools NOT Included in the Service Kit**

Item #	Part No.	Qty	Description	Drawing No.	Dwg Item #
2-4-1	Commercially Available	1	Acetone or Isopropyl Alcohol	N/A	N/A
2-4-2	Commercially Available	1	Deburr Tool	N/A	N/A
2-4-3	Commercially Available	1	#48 (0.076") Drill Bit	N/A	N/A

### 3. General

The instructions contained within this Field Service Instruction provide detailed steps for the application of a fay surface seal onto the wing skin lap joint underneath both wing fuel bays.

**▲ NOTE ▲**

The following work procedures must be conducted on both wings. It is at the technician's discretion if tasks are conducted simultaneously on both sides of the aircraft; however the procedural progression and safety precautions must be followed.

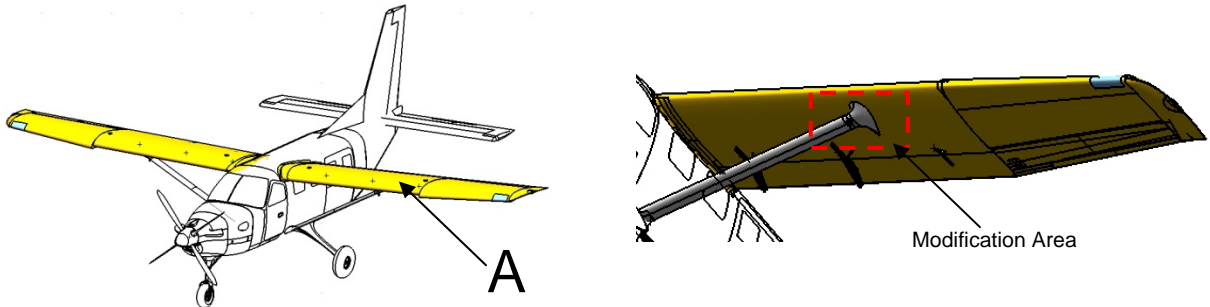
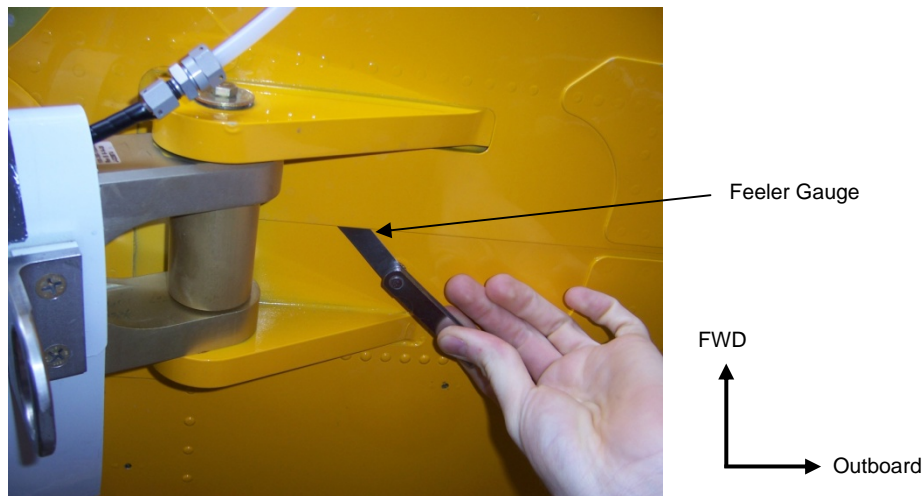

**Figure 3-1: Wing Modification Area**

### 4. Preparation

#### 4.1 Wing Fairing Removal

1. Remove the upper strut fairings (P/N 100-250-0501 and 100-250-0502), on both the left and right wings, by removing the attaching hardware.
2. Using a feeler gauge, inspect the lap joint in the modification area for a fay surface seal.



**Figure 4-1: Fay surface Seal Access Hole Location**

- a. If a fay surface seal is not present contact Quest Customer Care to order the required sealant. When the sealant has been received, proceed to **Section 5**.
- b. If a fay surface seal is present, reinstall the upper strut fairings and proceed to **Section 6**.

## 5. Instructions

### 5.1 Surface Preparation

Clean the area indicated in Figure 5-1 with a lint-free cloth and acetone or isopropyl alcohol.

### 5.2 Drill Procedures

1. Place a metal shim in between the outer and underlying skin.
2. Using a #48 (0.076") drill bit, drill an access hole through the outer skin in the area identified in **Figure 5-1**.

#### **⚠ CAUTION ⚠**

While drilling the access hole, only drill through the outer skin and do not penetrate the underlying skin. If the underlying skin is penetrated, contact Quest Aircraft for further instructions.

3. Remove the metal shim in between the outer and underlying skin.
4. Inspect the metal shim to ensure that there is no evidence of the drill bit passing through the shim.
5. Round, deburr, and clean the access hole.

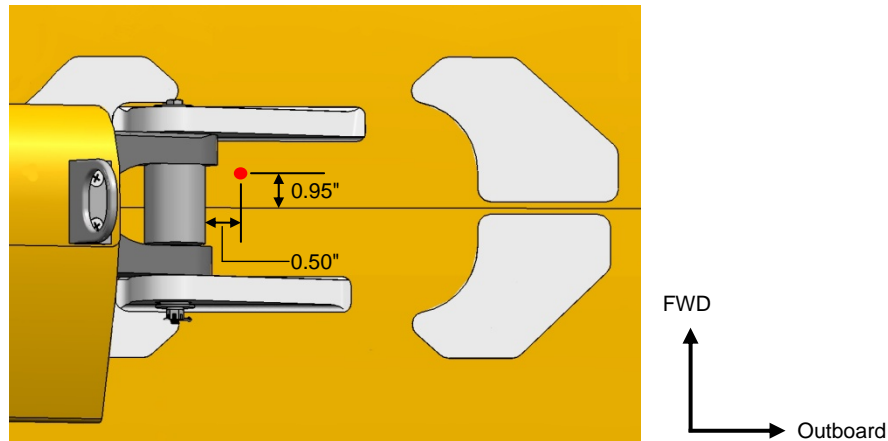

**Figure 5-1: Fay surface Seal Access Hole Location**

### 5.3 Sealant Installation

1. Temporarily install the polyurethane protective tape (P/N 8672) as needed between the forward lift strut lug and the aircraft skin, in the area shown in **Figure 5-2**, to maintain the aircraft skin position during the installation of the fay seal.

#### **⚠ NOTE ⚠**

The tape is intended to act as a shim and multiple layers of the polyurethane tape may be required. The protective backing *should not* be removed.

2. Mix a small amount of sealant, ensuring to follow all manufacturer's safety and cure time instructions.

3. Using a fine tipped syringe, carefully inject 0.8 cc – 1.5 cc of sealant into the access hole.
4. Using a dry cloth, remove any excess sealant.

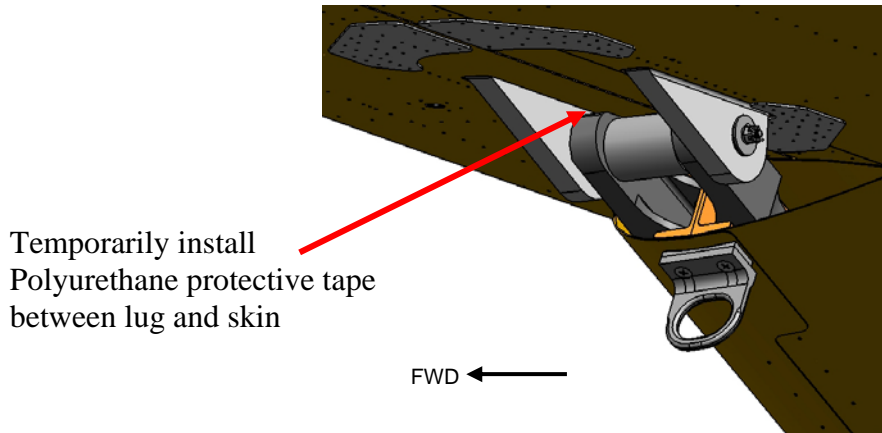

**Figure 5-2: Shim Installation**

5. Position a 2x4 piece of wood or equivalent under the aircraft wing as shown in **Figure 5-3**, creating a slight upward pressure on the aircraft skin beneath the fay surface seal to prevent any deformation of the aircraft skin.

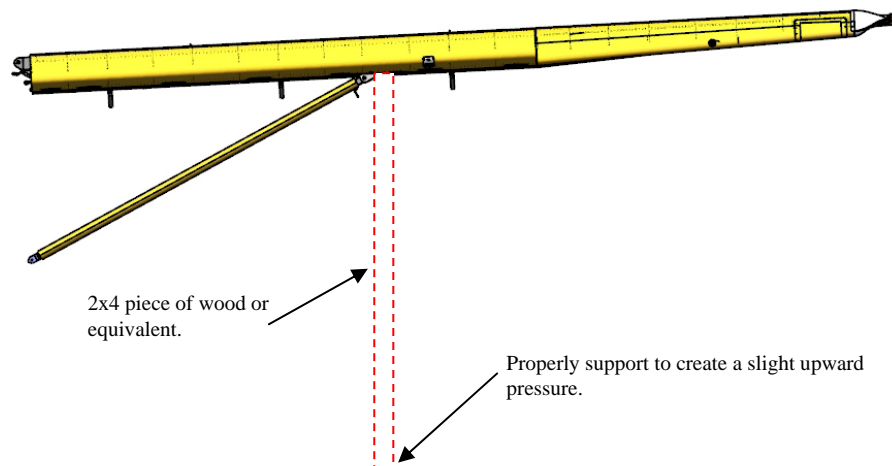

**Figure 5-3: Shim Installation**

#### **5.4 Complete Sealant Installation on Both Wings**

Complete the work described in **Sections 5.1** through **Section 5.3** on both wings.

#### **5.5 Wing Fairing Installation**

1. Remove any polyurethane protective tape installed in **Section 5.3**.
2. Reinstall the upper strut fairings, on both the left and right wings.

### **6. Completion**

Upon completion, record all the work performed in the appropriate maintenance records.

**---END---**