

**\*MANDATORY SERVICE BULLETIN\*****NUMBER:** SB11-07**REVISION:** 00**DATE:** 07/01/2011**SUBJECT:** Nose Gear Piston Tube Cap Replacement**EFFECTIVITY:**

KODIAK 100 Series Aircraft, Serial Numbers 100-0046 and 100-0052.

**SUBJECT:**

Quest has become aware of an issue with the nose gear piston tube cap (P/N **100-412-0103**) on certain airplanes. Our vendor inadvertently manufactured these parts from a different alloy of material than required in our approved design. We have investigated the effect of this deviation and have concluded in conjunction with FAA engineering that this does not affect the functionality or safety of the part. However, due to the parts not meeting the exact type design specifications, we are issuing a recall of the part. A new part will be provided by Quest, and should be used to replace the noncomplying part on your airplane.

**ACTION:**

Quest is mandating the replacement of the nose gear piston tube cap on the affected aircraft. Refer to the next part of this Service Bulletin for instructions on how to remove the old nose gear piston tube cap and install the new nose gear piston tube cap.

**COMPLIANCE:**

This Service Bulletin must be completed at the next major nose gear servicing.

**AFFECTED PARTS:**Nose Gear Piston Tube Cap (P/N **100-412-0103**)**AFFECTED MANUALS AND PUBLICATIONS:**

None

**MANPOWER:****Estimated Manhours:** 2**Minimum Number of Persons Needed:** 1**WEIGHT AND BALANCE:**

The procedure contained in this Service Bulletin is negligible to the weight and balance of the aircraft.

Quest Aircraft Company, LLC  
© Copyright 2011  
All Rights Reserved

No part of this document may be reproduced, copied, transmitted, disseminated, downloaded or stored in any storage medium, for any purpose without the express prior written consent of Quest Aircraft Company, LLC.

**CREDIT AND WARRANTY INFORMATION:**

Quest Aircraft Company will reimburse for the cost of this replacement up to \$75.00 per hour, for aircraft still under factory warranty. For reimbursement send Quest Aircraft Company a copy of the modification record and serial number of the aircraft on which the modification was completed.

**Quest Customer Service**  
**Service Bulletin SB11-07**  
**Phone: (208)263-1111 Toll Free: 1(866)263-1112**  
**Email: [customercare@questaircraft.com](mailto:customercare@questaircraft.com)**

**FAA APPROVED:**

The resultant replacement of the nose gear piston tube cap, as described in this Service Bulletin, has shown compliance with the applicable Federal Aviation Regulations and is FAA approved.

**COMPLETION:**

Record all work performed in the *KODIAK 100 Maintenance Log Books*.

**SPECIAL INSTRUCTIONS:**

Replacement of the nose gear piston tube cap (P/N **100-412-0103**) is most easily done during the course of major nose gear servicing. However, the referenced part can be replaced while the nose gear is installed on the airplane, if major servicing is not required. The instructions in this Service Bulletin should be followed if the part is replaced while the nose gear remains installed on the airplane.

## LOG OF CHANGES

Revision:	Date:	Description of Change:
00	07/01/2011	Initial Release

## ATTACHED DOCUMENTS

Document #:	Date:	Document Title:
N/A	N/A	N/A

## PARTS, TOOLS, AND EQUIPMENT

The following parts, tools, and equipment are needed in order to complete the instructions contained within.

Parts or Tools included in this Service Kit:

Part Number	Description	Quantity
<b>100-412-0103</b>	Replacement Nose Gear Piston Tube Cap	1
<b>M83461/1-328</b>	O-ring	1
<b>Shop Aid</b>	Pulling Pin Shop Aid	1

Special Parts or Tools required that are NOT provided in this Service Kit:

Tool Name	Description	Quantity
<b>Slide Hammer</b>	Equivalent may be used.	1
<b>Parker Lube</b>	Equivalent may be used.	AR

## 1. REMOVAL OF OLD TUBE CAP

1. Suitably secure and jack the airplane so that the nose wheel can be removed (refer to **Chapter 7** of the *KODIAK 100 Airplane Maintenance Manual*).
2. Remove the nose wheel (refer to **Chapter 32** in the *Airplane Maintenance Manual*).
3. Bleed pressure off of the nose gear using the high pressure air valve.
4. Remove the capturing bolt from the nose gear piston tube cap (P/N **100-412-0103**). See **Figure 1-1**.
5. Install the shop aid (supplied with this Service Bulletin kit) through the 3/8" capturing bolt hole, as shown in **Figure 1-2**.



**CAUTION:** To avoid damaging the chrome tube, ensure that the shop aid is centered in the piston tube cap, as shown in **Figure 1-3**.

6. Using a slide hammer (or equivalent), pull down on the tube cap to remove it from the nose gear.



**NOTE:** When the tube cap is removed, 5606 hydraulic oil will drain from the chrome tube. A drain pan, or similar tool, should be on hand.

## 2. INSTALLATION OF NEW TUBE CAP

1. Ensure that there are no sharp edges where the 3/8" capturing bolt passes through the inside of the chrome piston tube. If sharp edges are found, deburr appropriately.
2. Install the new nose gear piston tube cap, using Parker lube (or equivalent) and the new supplied O-ring (P/N **M83461/1-328**).
3. Align the hole in the new tube cap with the capturing hole in the chrome tube, and install the 3/8" capturing bolt.
  - A. Looking up through the bottom of the nose gear, ensure that the capturing bolt passes through the capturing bolt hole in the new tube cap. See **Figure 1-4**.
4. Service the nose gear shock strut (refer to **Chapter 12** of the *Airplane Maintenance Manual*).
5. Reinstall the nose wheel.

## 3. COMPLETION

1. Destroy the unserviceable, removed nose gear piston tube cap.
2. Record all work performed in the appropriate Maintenance Log books.

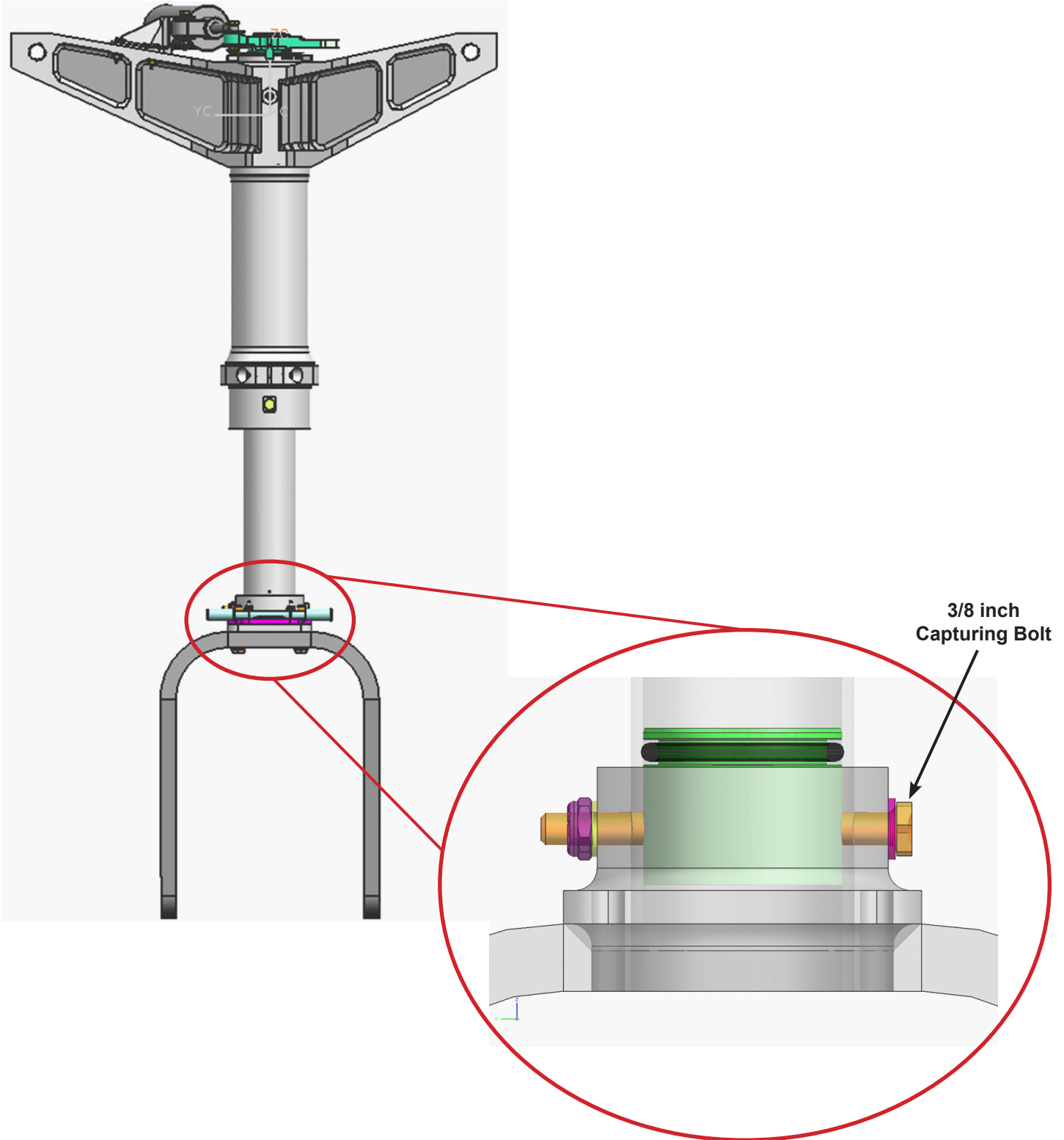

Figure 1-1 – View of the Nose Gear (with expanded view of nose gear piston tube cap)

**NOTE:** In the Figure above, the nose gear piston tube cap (P/N 100-412-0103) is shaded green, and the tow peg and fasteners are removed, for clarity.

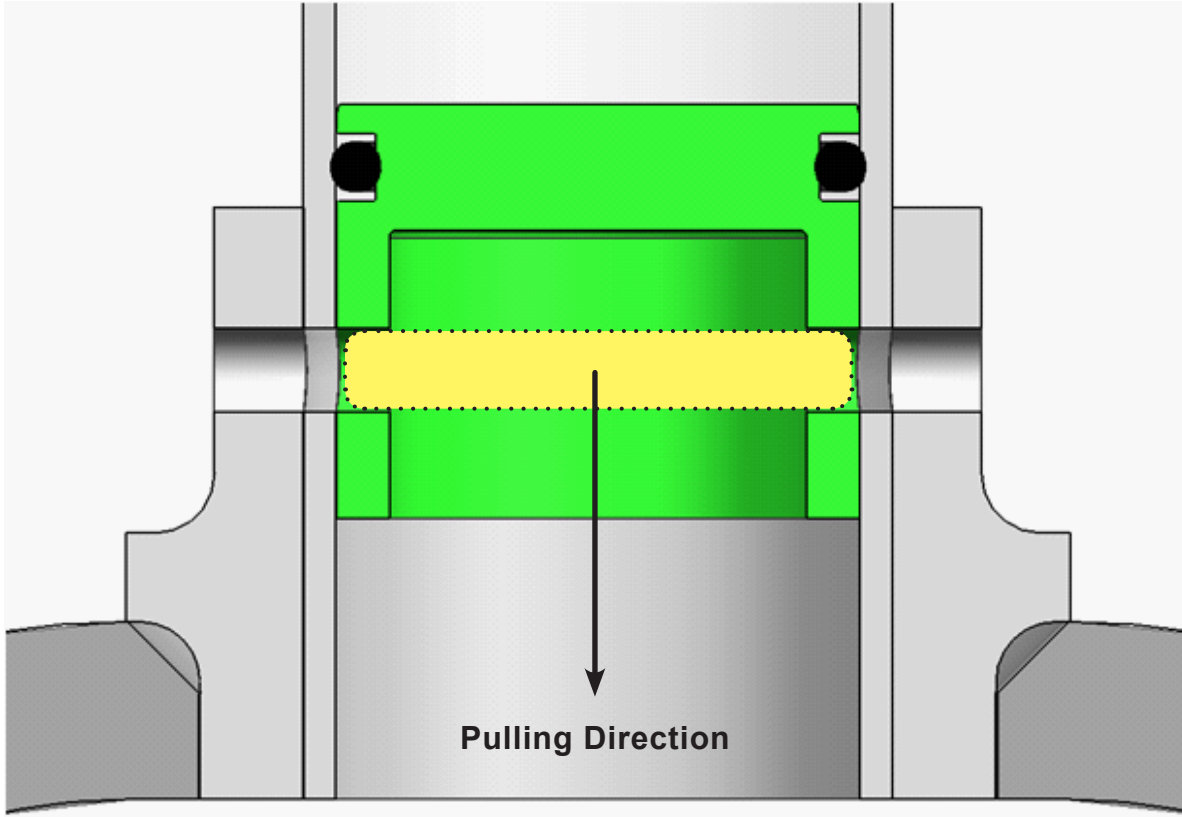

Figure 1-2 – Cross Section View Showing Pulling Pin in Place

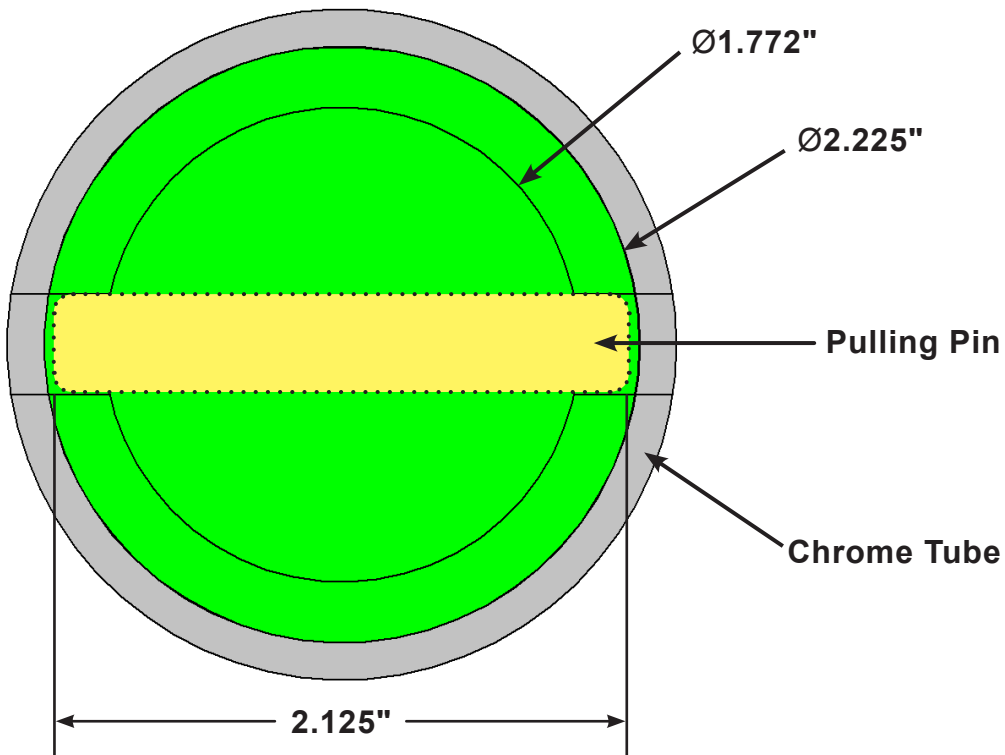
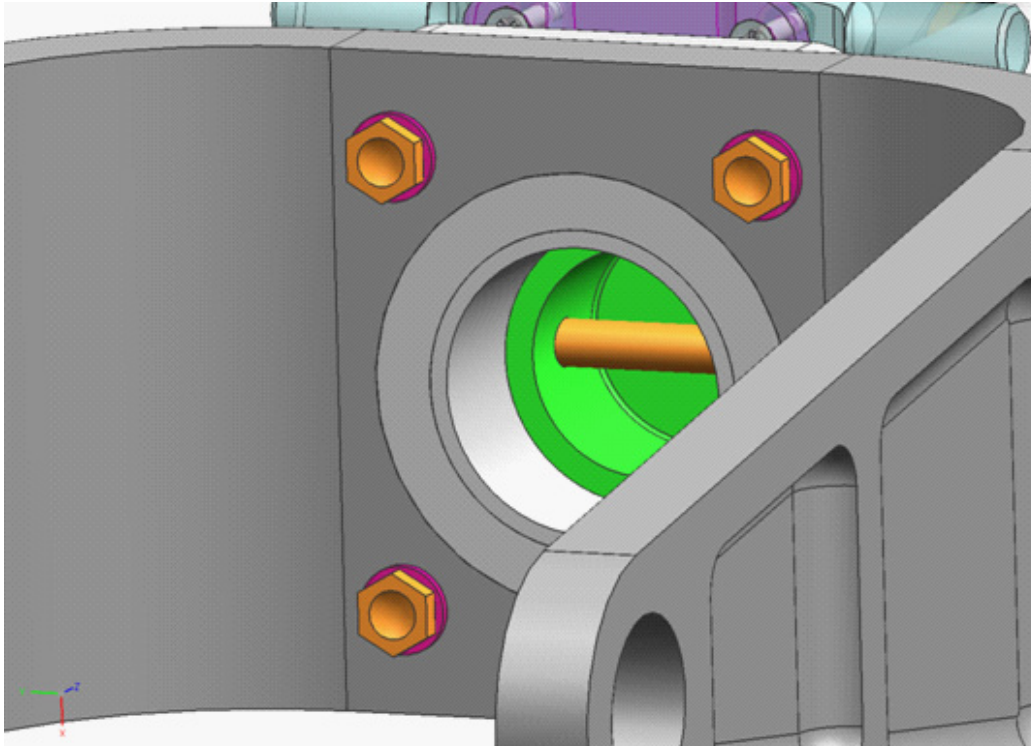

Figure 1-3 – Cross Section View Showing Clearance for Pulling Pin



**Figure 1-4 – Capturing Bolt Installed through the Hole in the New Tube Cap**

*This Page Intentionally Left Blank*