

MANDATORY SERVICE BULLETIN**NUMBER:** SB12-01**REVISION:** 00**DATE:** January 31, 2012**SUBJECT:** AUTOPILOT SERVO CHAFE PROTECTION INSTALLATION**EFFECTIVITY:**

KODIAK 100 Series Aircraft Serial Numbers: 100-0001 through 100-0061

SUMMARY:

The accompanying Field Service Instruction provides guidance for the installation of cable guards onto the autopilot servo.

COMPLIANCE:

This Mandatory Service Bulletin must be complied with on or before the next 100 Hour Inspection, Annual Inspection, or scheduled maintenance, whichever comes first.

ATTACHED DOCUMENTS:

Document #:	Revision:	Document Title:
FSI-034	01	AUTOPILOT SERVO CHAFE PROTECTION INSTALLATION

FAA APPROVAL STATUS:

The instructions attached to this Service Bulletin have demonstrated compliance with all applicable Federal Aviation Regulations and are approved by the Federal Aviation Administration.

CREDIT AND WARRANTY INFORMATION:

Quest Aircraft Company will reimburse for the cost of compliance with this Service Bulletin up to \$85.00. For reimbursement send Quest Aircraft Company a copy of the maintenance record, completed KODIAK 100 Warranty Claim Form, and an invoice that does not exceed the amount listed above.

Quest Customer Service**Service Bulletin: SB12-01****Phone: (208)263-1111 Toll Free: 1(866)263-1112****Email: Customercare@questaircraft.com****SPECIAL INSTRUCTIONS:**

None.

MANDATORY SERVICE BULLETIN***MANDATORY SERVICE BULLETIN***



FIELD SERVICE INSTRUCTION

TITLE: Autopilot Servo Chafe Protection Installation
SERIAL RANGE: 100-0001 thru 100-0061
JASC CODE: 2215

PAGE: 1 of 8
REPORT NO.: FSI-034
REVISION: 01

SUBJECT

This Field Service Instruction provides guidance for the installation of cable guards onto the autopilot servo.

AFFECTED MANUALS AND PUBLICATIONS

None

INDUSTRY REFERENCES

None

WEIGHT AND BALANCE

Negligible

MANPOWER

The estimated man-hours and minimum number of persons required to perform this Field Service Instruction are listed below. The "Minimum Persons" refers only to maintenance personnel or installers, and unless otherwise specified within this instruction does not include additional personnel that may be needed solely to comply with safety requirements (for example, safety observers that are not performing tasks within this instruction). It is the responsibility of maintenance personnel to comply with safety requirements, including having a safety observer available as needed.

Estimated Man-hours: 1 hour

Minimum Persons: 1 person

If more than the minimum personnel perform this instruction, the actual man-hours required may be reduced due to increased efficiencies. As appropriate, Quest encourages the use of additional personnel; manhour estimates are based on the minimum personnel required.

RECORD OF COMPLETION

- Update the appropriate maintenance records.

Quest Aircraft Company, LLC
1200 Turbine Drive
Sandpoint, ID 83864



FIELD SERVICE INSTRUCTION

TITLE: Autopilot Servo Chafe Protection Installation

SERIAL RANGE: 100-0001 thru 100-0061

JASC CODE: 2215

PAGE: 2 of 8

REPORT NO.: FSI-034

REVISION: 01

REVISION RECORD

REV	PAGE	CHANGE DESCRIPTION
00	All	Initial Release
01	All	Serial Range updated from (100-0021 thru 100-0061) to (100-0001 thru 100-0061)



TITLE:

FIELD SERVICE INSTRUCTION

Autopilot Servo Chafe Protection Installation

SERIAL RANGE:

100-0001 thru 100-0061

JASC CODE:

2215

PAGE:

3 of 8

REPORT NO.:

FSI-034

REVISION:

01

TABLE OF CONTENTS

REVISION RECORD.....	2
TABLE OF CONTENTS.....	3
1. Special Safety Instructions.....	4
1.1 Warnings	4
1.2 Cautions.....	4
1.3 Notes.....	4
2. Parts, Tools, and Equipment	4
Table 2-1: Parts and Tools Included in the Service Kit.....	4
Table 2-2: Consumables Included in the Service Kit.....	4
Table 2-3: Serial-Number-Specific Parts Included in the Service Kit	4
Table 2-4: Parts and Tools NOT Included in the Service Kit	4
3. General.....	5
Figure 3-1: Autopilot Servo Overview.....	5
4. Preparation	5
4.1 Aircraft Power	5
4.2 Aft Bulkhead Removal	5
5. Instructions.....	6
5.1 Component Removal	6
Figure 5-1: Component Identification.....	6
5.2 Component Installation	6
Figure 5-2: Standoff and Roller Assembly	6
Figure 5-3: Standoff and Roller Assembly	7
5.3 Inspection	8
6. Completion.....	8



FIELD SERVICE INSTRUCTION

TITLE: Autopilot Servo Chafe Protection Installation
SERIAL RANGE: 100-0001 thru 100-0061
JASC CODE: 2215

PAGE: 4 of 8
REPORT NO.: FSI-034
REVISION: 01

1. Special Safety Instructions

1.1 Warnings

Failure to comply with “Warnings” contained in this instruction may result in financial loss, significant delay in the completion time, and/or serious injury to personnel.

1.2 Cautions

Failure to comply with “Cautions” contained in this instruction may result in the destruction of components, unnecessary complications, the need to reverse completed work, and/or delays in the completion time.

1.3 Notes

“Notes” are provided when additional information may lead to an increase in efficiency.

2. Parts, Tools, and Equipment

The following tables describe the parts, tools, and equipment necessary to successfully complete this instruction. Where applicable, reference to drawings provided with this instruction is provided.

Table 2-1: Parts and Tools Included in the Service Kit

Item #	Part No.	Qty	Description	Drawing No.	Dwg Item #
2-1-1	100-630-2105	1	Autopilot Cable Guard	N/A	N/A
2-1-2	41281	1	S-Tec® Roller	N/A	N/A
2-1-3	4410-3	1	S-Tec® Cable Guard Standoff	N/A	N/A

Table 2-2: Consumables Included in the Service Kit

Item #	Part No.	Qty	Description	Drawing No.	Dwg Item #
2-2-1	LOCTITE-242-0.5ML	1	Loctite® 242 Blue Threadlocking Compound ¹	N/A	N/A

¹: Consumables may be shipped separately from the primary kit.

Table 2-3: Serial-Number-Specific Parts Included in the Service Kit

Item #	Part No.	Qty	Description	Drawing No.	Dwg Item #
2-3-1	N/A	N/A	N/A	N/A	N/A

Table 2-4: Parts and Tools NOT Included in the Service Kit

Item #	Part No.	Qty	Description	Drawing No.	Dwg Item #
2-4-1	N/A	N/A	N/A	N/A	N/A

3. General

This Field Service Instruction provides information for the installation of chafe protection to the autopilot pitch servo.

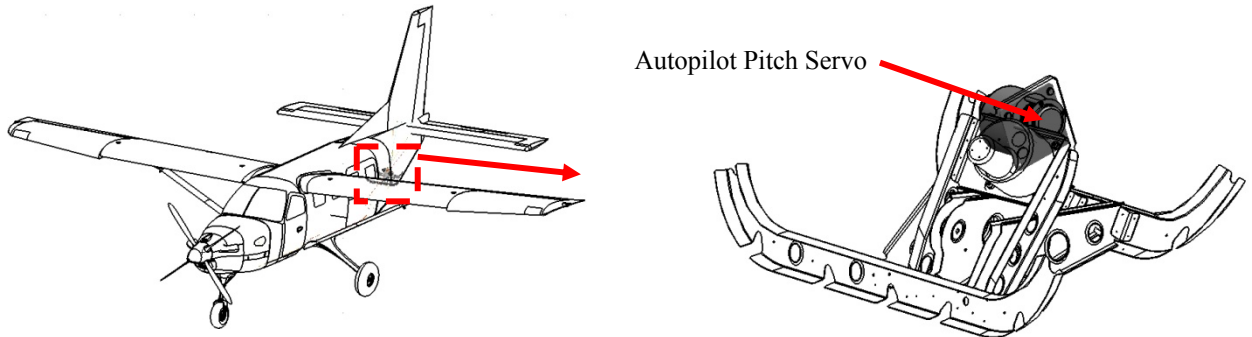

Figure 3-1: Autopilot Servo Overview

4. Preparation

4.1 Aircraft Power

Ensure that the master switch is in the “OFF” position.

4.2 Aft Interior Bulkhead Removal

Remove the hardware securing the aft interior bulkhead, and remove the bulkhead from the aircraft.

5. Instructions

5.1 Component Removal

1. Remove the four (4) screws, four (4) lock washers, the servo cap, and the one (1) top standoff shown in **Figure 5-1**. Retain the four (4) screws, and discard two (2) of the lock washers and the one (1) standoff.

▲ NOTE ▲

The standoff has a threaded end which secures it to the servo housing. In order to remove the standoff from the autopilot servo assembly, unscrew it from the housing.

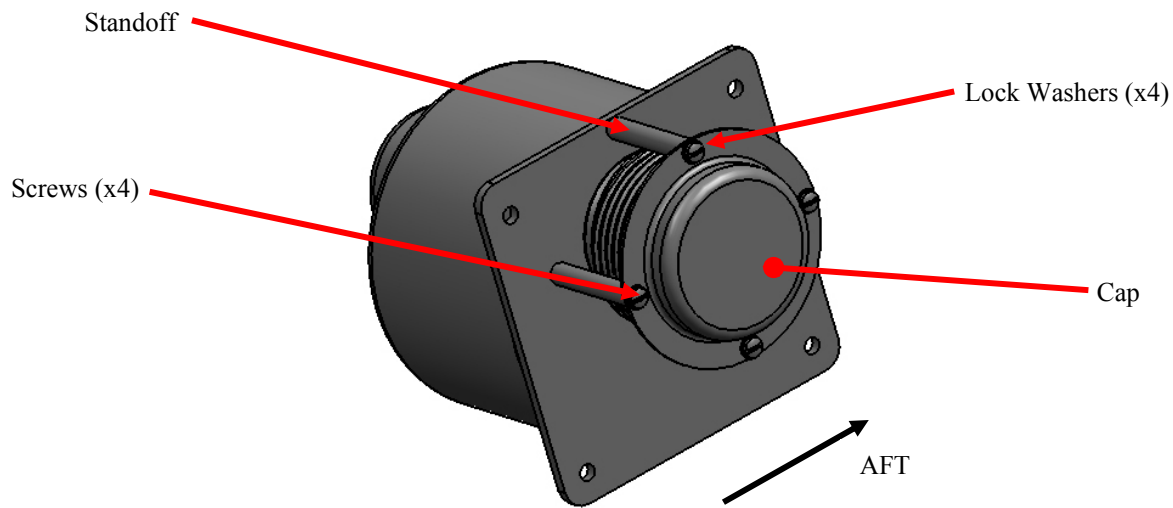

Figure 5-1: Component Identification

5.2 Component Installation

1. Insert the threaded end of the standoff (P/N 4410-3) into the servo housing and tighten to finger tightness.

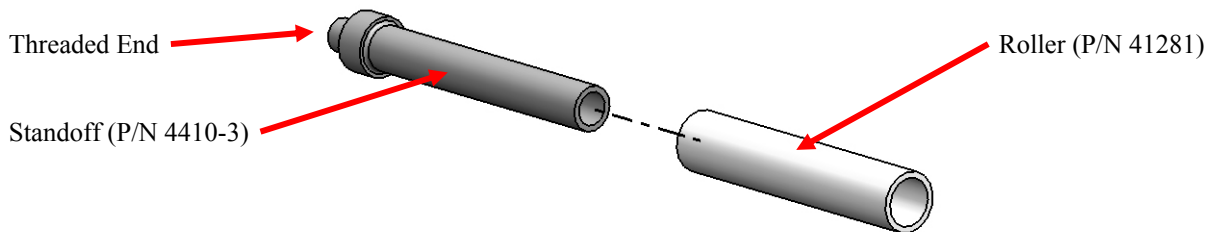

Figure 5-2: Standoff and Roller Assembly

2. Install the roller (P/N 41281) onto the standoff (P/N 4410-3) as shown in **Figure 5-2**.

3. Install the cable guard (P/N 100-630-2105) and cap as shown in **Figure 5-3**. Apply Loctite (P/N LOCTITE-242-0.5ML) to the threads of the two (2) screws that secure the cable guard just prior to installation. Using a 180° pattern, tighten all screws to finger tight, then tighten with a screwdriver. Ensure that the cap sits evenly on all standoffs.

⚠ CAUTION ⚠

Only apply enough Loctite to cover the threads of the two screws. After the screws have been installed, remove any excess Loctite that may appear. Ensure that no Loctite has seeped into the autopilot cables or servo assembly.

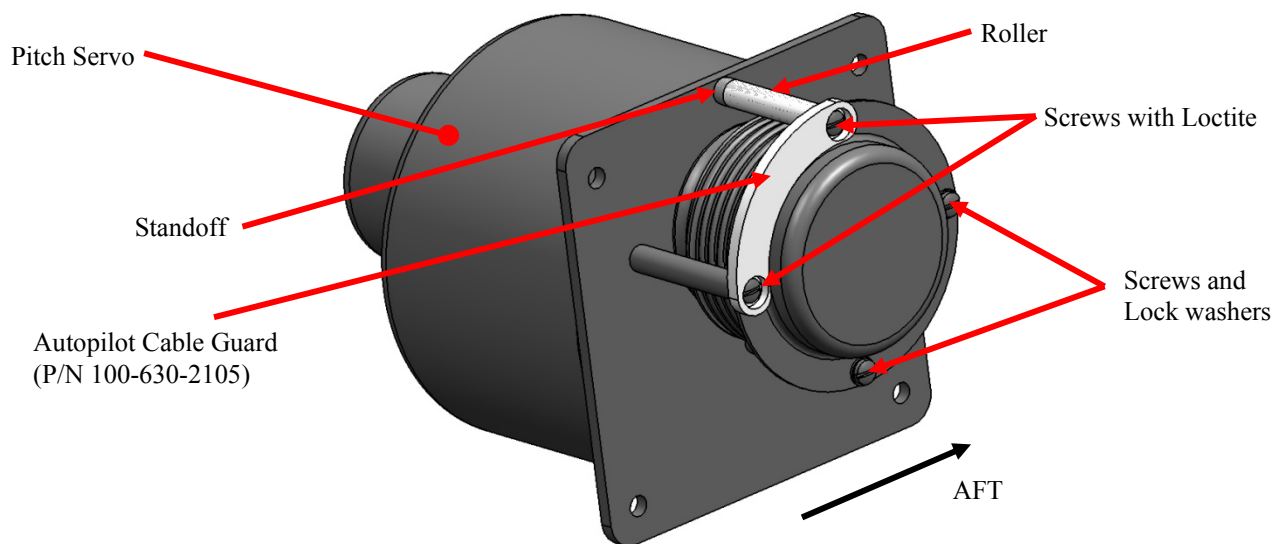

Figure 5-3: Standoff and Roller Assembly

5.3 Inspection

1. Inspect the autopilot control cables in accordance with the *KODIAK 100 Maintenance Manual*, Chapter 20. If any damage is located, contact Quest Aircraft Company for further instructions.
2. Inspect the aft empennage for any foreign objects or debris, and remove as necessary. If any damage is located, contact Quest Aircraft Company for further instructions.
3. Verify that the bridle cable routing is tight against the servo motor, located inside standoffs, and around the entire circumference of the servo drive shaft.
4. Verify that the elevator cable is located above the new roller installed in **Section 5.2**.

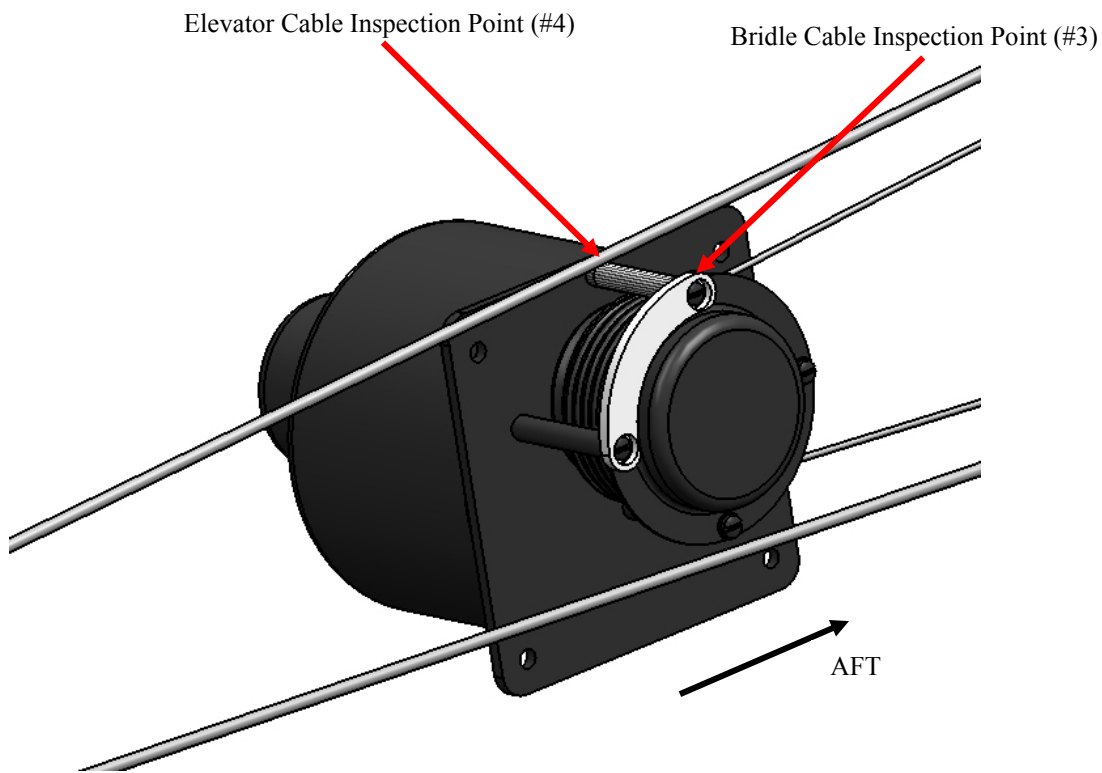

Figure 5-4: Control Cable Inspection Locations

5. Turn the master switch to the “ON” position, and perform a functional check of the servo.
6. With an observer in the aft section of the aircraft, move the elevator through its full motion. If any interference occurs, make adjustments as necessary to eliminate.
7. Reinstall the aft interior bulkhead using the hardware removed in **Section 4.2**.

6. Completion

Upon completion, record all work performed in the appropriate maintenance records.

---END---



FIELD SERVICE INSTRUCTION

TITLE: Autopilot Servo Chafe Protection Installation
SERIAL RANGE: 100-0001 thru 100-0061
JASC CODE: 2215

PAGE: 1 of 8
REPORT NO.: FSI-034
REVISION: 01

SUBJECT

This Field Service Instruction provides guidance for the installation of cable guards onto the autopilot servo.

AFFECTED MANUALS AND PUBLICATIONS

None

INDUSTRY REFERENCES

None

WEIGHT AND BALANCE

Negligible

MANPOWER

The estimated man-hours and minimum number of persons required to perform this Field Service Instruction are listed below. The "Minimum Persons" refers only to maintenance personnel or installers, and unless otherwise specified within this instruction does not include additional personnel that may be needed solely to comply with safety requirements (for example, safety observers that are not performing tasks within this instruction). It is the responsibility of maintenance personnel to comply with safety requirements, including having a safety observer available as needed.

Estimated Man-hours: 1 hour

Minimum Persons: 1 person

If more than the minimum personnel perform this instruction, the actual man-hours required may be reduced due to increased efficiencies. As appropriate, Quest encourages the use of additional personnel; manhour estimates are based on the minimum personnel required.

RECORD OF COMPLETION

- Update the appropriate maintenance records.

Quest Aircraft Company, LLC
1200 Turbine Drive
Sandpoint, ID 83864



FIELD SERVICE INSTRUCTION

TITLE: Autopilot Servo Chafe Protection Installation

SERIAL RANGE: 100-0001 thru 100-0061

JASC CODE: 2215

PAGE: 2 of 8
REPORT NO.: FSI-034
REVISION: 01

REVISION RECORD

REV	PAGE	CHANGE DESCRIPTION
00	All	Initial Release
01	All	Serial Range updated from (100-0021 thru 100-0061) to (100-0001 thru 100-0061)



TITLE:

FIELD SERVICE INSTRUCTION

Autopilot Servo Chafe Protection Installation

SERIAL RANGE:

100-0001 thru 100-0061

JASC CODE:

2215

PAGE:

3 of 8

REPORT NO.:

FSI-034

REVISION:

01

TABLE OF CONTENTS

REVISION RECORD.....	2
TABLE OF CONTENTS.....	3
1. Special Safety Instructions.....	4
1.1 Warnings	4
1.2 Cautions.....	4
1.3 Notes.....	4
2. Parts, Tools, and Equipment	4
Table 2-1: Parts and Tools Included in the Service Kit.....	4
Table 2-2: Consumables Included in the Service Kit.....	4
Table 2-3: Serial-Number-Specific Parts Included in the Service Kit	4
Table 2-4: Parts and Tools NOT Included in the Service Kit	4
3. General.....	5
Figure 3-1: Autopilot Servo Overview.....	5
4. Preparation	5
4.1 Aircraft Power	5
4.2 Aft Bulkhead Removal	5
5. Instructions.....	6
5.1 Component Removal	6
Figure 5-1: Component Identification.....	6
5.2 Component Installation	6
Figure 5-2: Standoff and Roller Assembly	6
Figure 5-3: Standoff and Roller Assembly	7
5.3 Inspection	8
6. Completion.....	8



FIELD SERVICE INSTRUCTION

TITLE: Autopilot Servo Chafe Protection Installation
SERIAL RANGE: 100-0001 thru 100-0061
JASC CODE: 2215

PAGE: 4 of 8
REPORT NO.: FSI-034
REVISION: 01

1. Special Safety Instructions

1.1 Warnings

Failure to comply with “Warnings” contained in this instruction may result in financial loss, significant delay in the completion time, and/or serious injury to personnel.

1.2 Cautions

Failure to comply with “Cautions” contained in this instruction may result in the destruction of components, unnecessary complications, the need to reverse completed work, and/or delays in the completion time.

1.3 Notes

“Notes” are provided when additional information may lead to an increase in efficiency.

2. Parts, Tools, and Equipment

The following tables describe the parts, tools, and equipment necessary to successfully complete this instruction. Where applicable, reference to drawings provided with this instruction is provided.

Table 2-1: Parts and Tools Included in the Service Kit

Item #	Part No.	Qty	Description	Drawing No.	Dwg Item #
2-1-1	100-630-2105	1	Autopilot Cable Guard	N/A	N/A
2-1-2	41281	1	S-Tec® Roller	N/A	N/A
2-1-3	4410-3	1	S-Tec® Cable Guard Standoff	N/A	N/A

Table 2-2: Consumables Included in the Service Kit

Item #	Part No.	Qty	Description	Drawing No.	Dwg Item #
2-2-1	LOCTITE-242-0.5ML	1	Loctite® 242 Blue Threadlocking Compound ¹	N/A	N/A

¹: Consumables may be shipped separately from the primary kit.

Table 2-3: Serial-Number-Specific Parts Included in the Service Kit

Item #	Part No.	Qty	Description	Drawing No.	Dwg Item #
2-3-1	N/A	N/A	N/A	N/A	N/A

Table 2-4: Parts and Tools NOT Included in the Service Kit

Item #	Part No.	Qty	Description	Drawing No.	Dwg Item #
2-4-1	N/A	N/A	N/A	N/A	N/A

3. General

This Field Service Instruction provides information for the installation of chafe protection to the autopilot pitch servo.

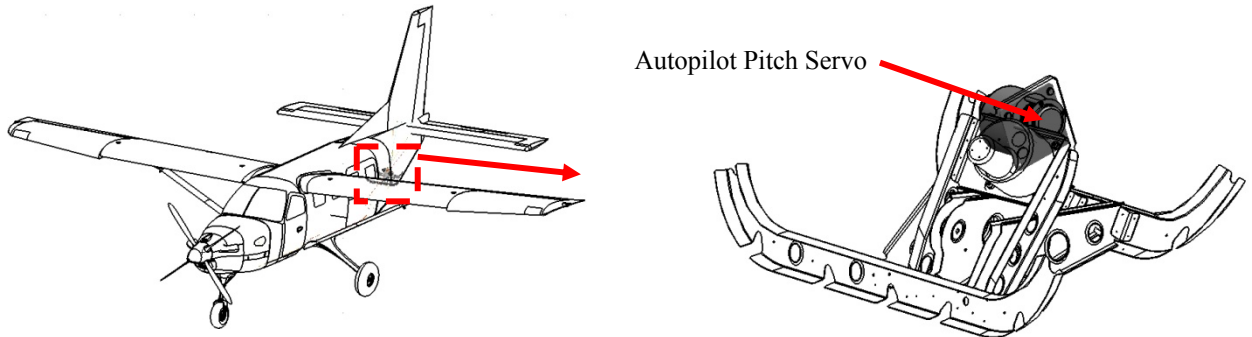

Figure 3-1: Autopilot Servo Overview

4. Preparation

4.1 Aircraft Power

Ensure that the master switch is in the “OFF” position.

4.2 Aft Interior Bulkhead Removal

Remove the hardware securing the aft interior bulkhead, and remove the bulkhead from the aircraft.

5. Instructions

5.1 Component Removal

1. Remove the four (4) screws, four (4) lock washers, the servo cap, and the one (1) top standoff shown in **Figure 5-1**. Retain the four (4) screws, and discard two (2) of the lock washers and the one (1) standoff.

▲ NOTE ▲

The standoff has a threaded end which secures it to the servo housing. In order to remove the standoff from the autopilot servo assembly, unscrew it from the housing.

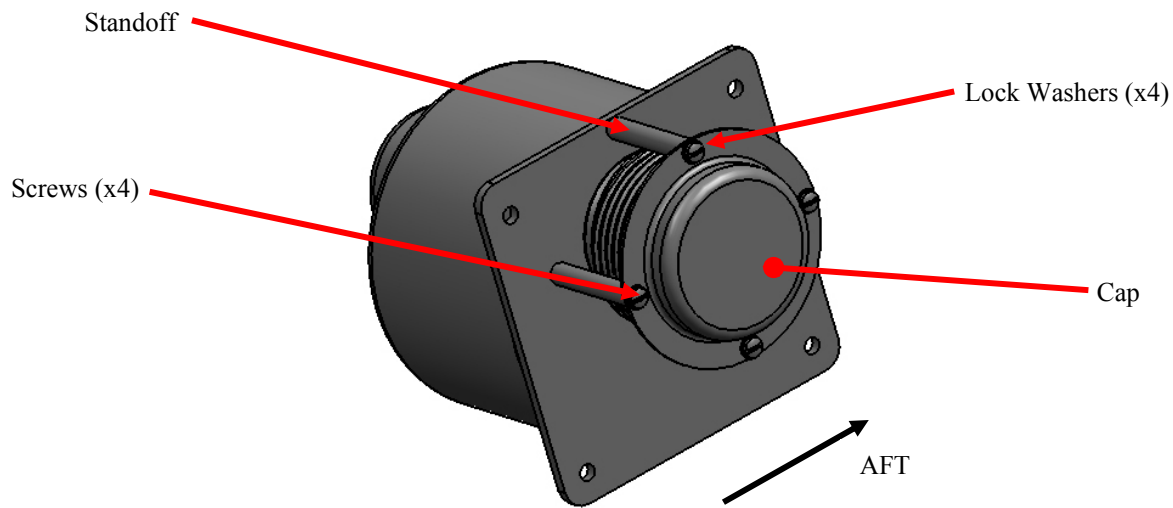

Figure 5-1: Component Identification

5.2 Component Installation

1. Insert the threaded end of the standoff (P/N 4410-3) into the servo housing and tighten to finger tightness.

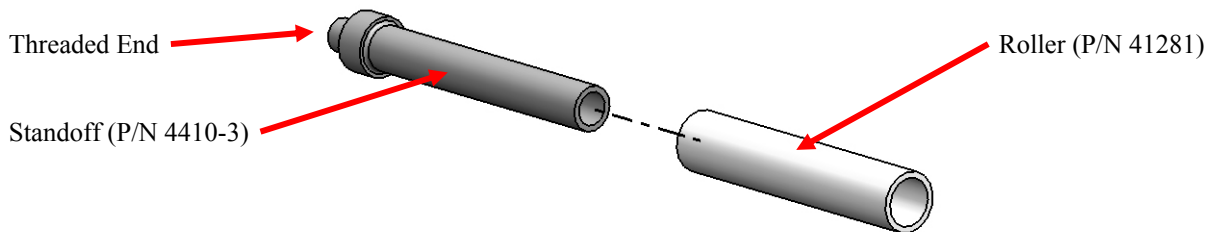

Figure 5-2: Standoff and Roller Assembly

2. Install the roller (P/N 41281) onto the standoff (P/N 4410-3) as shown in **Figure 5-2**.

3. Install the cable guard (P/N 100-630-2105) and cap as shown in **Figure 5-3**. Apply Loctite (P/N LOCTITE-242-0.5ML) to the threads of the two (2) screws that secure the cable guard just prior to installation. Using a 180° pattern, tighten all screws to finger tight, then tighten with a screwdriver. Ensure that the cap sits evenly on all standoffs.

⚠ CAUTION ⚠

Only apply enough Loctite to cover the threads of the two screws. After the screws have been installed, remove any excess Loctite that may appear. Ensure that no Loctite has seeped into the autopilot cables or servo assembly.

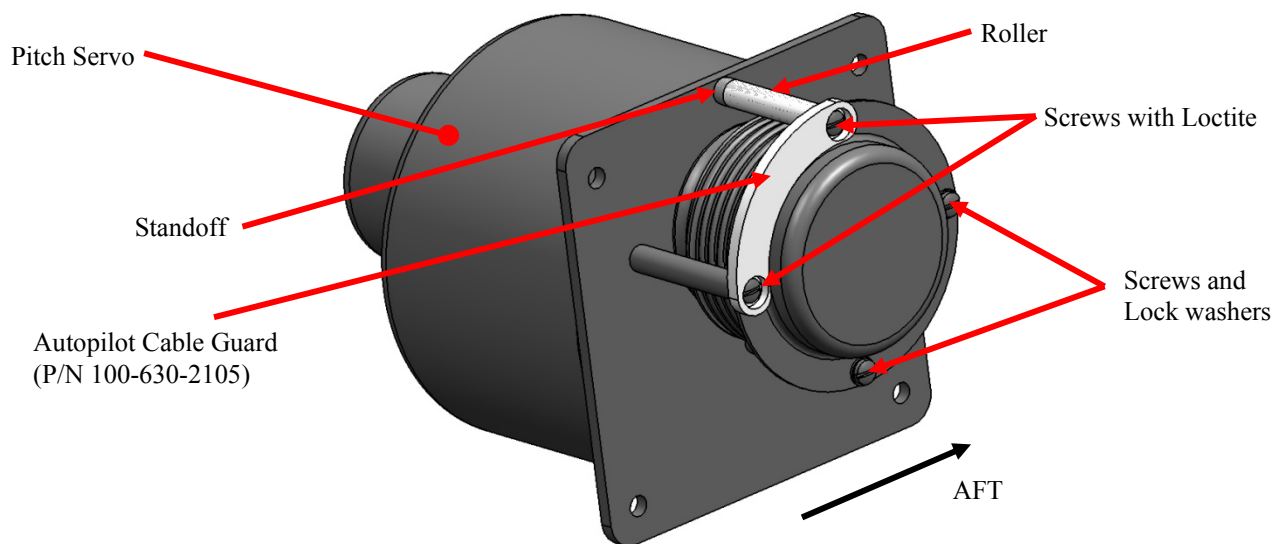

Figure 5-3: Standoff and Roller Assembly

5.3 Inspection

1. Inspect the autopilot control cables in accordance with the *KODIAK 100 Maintenance Manual*, Chapter 20. If any damage is located, contact Quest Aircraft Company for further instructions.
2. Inspect the aft empennage for any foreign objects or debris, and remove as necessary. If any damage is located, contact Quest Aircraft Company for further instructions.
3. Verify that the bridle cable routing is tight against the servo motor, located inside standoffs, and around the entire circumference of the servo drive shaft.
4. Verify that the elevator cable is located above the new roller installed in **Section 5.2**.

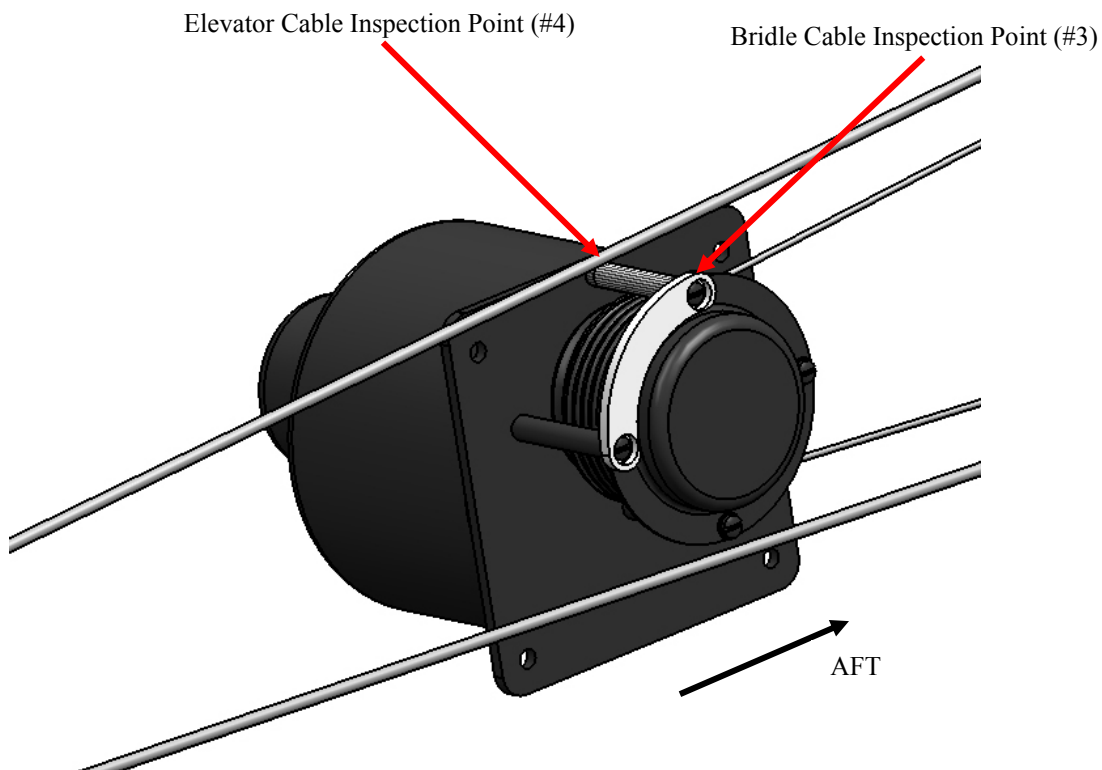

Figure 5-4: Control Cable Inspection Locations

5. Turn the master switch to the “ON” position, and perform a functional check of the servo.
6. With an observer in the aft section of the aircraft, move the elevator through its full motion. If any interference occurs, make adjustments as necessary to eliminate.
7. Reinstall the aft interior bulkhead using the hardware removed in **Section 4.2**.

6. Completion

Upon completion, record all work performed in the appropriate maintenance records.

---END---